



## Quick Start Guide

Guide de Mise en route  
Guía de inicio rápido  
Guia de consulta rápida  
Schnellstart-Anleitung  
Guida rapida



The Kodak trademark and trade dress are used under license from Kodak.

La marque de commerce Kodak et son apparence sont utilisées sous licence Kodak.

La marca y la imagen comercial Kodak son usadas bajo licencia de Kodak.

A marca e a imagem comercial Kodak são usadas sob licença da Kodak.

Kodak und die Kodak-Markenausstattung werden unter Lizenz von Kodak genutzt.

Il marchio Kodak ed il trade dress Kodak sono usati sotto licenza di Kodak.

© 2013 by JK Imaging Ltd. All rights reserved.

JK Imaging Ltd. 1411 W. 190th Street, Suite 550, Gardena, CA 90248, USA

www.kodakcamera.jkilt.com



CR236080599-0

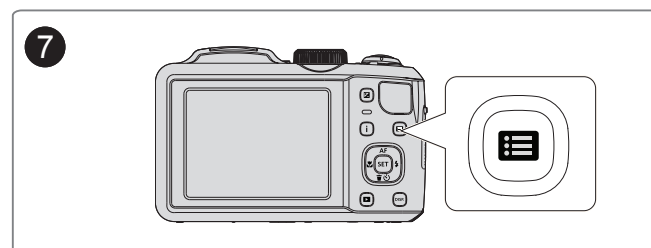
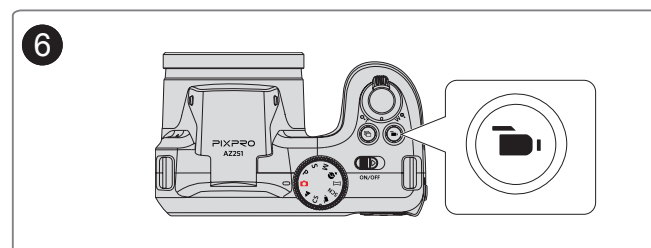
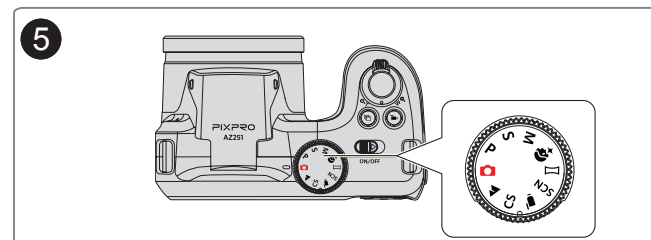
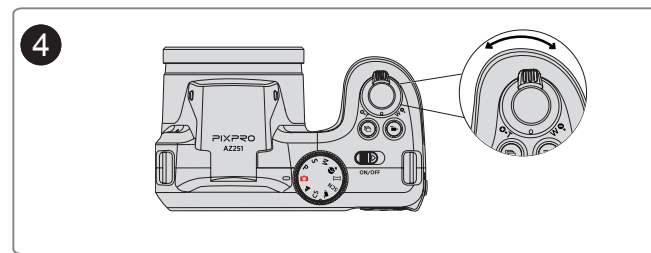
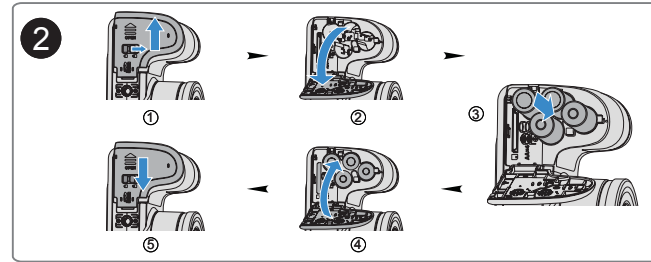
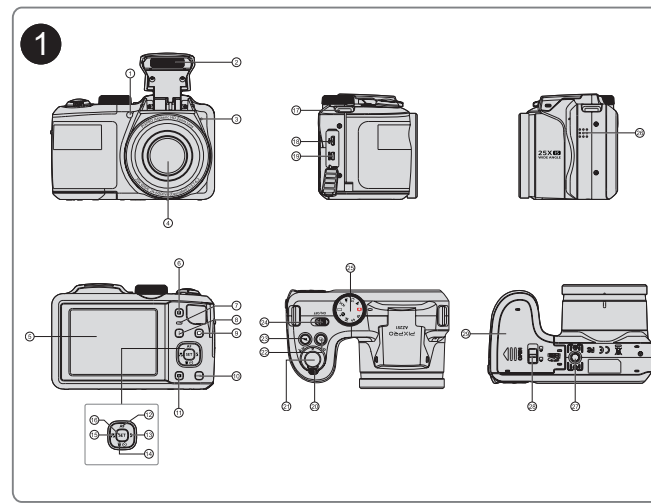

### 1 Camera Views

1	AF Assist Beam/Timer Indicator	16	SET Button
2	Flash Lamp	17	Strap Buckles
3	Microphone	18	USB Port
4	Lens	19	HDMI Port
5	LCD Screen	20	Zoom Lever
6	Exposure Compensation Button	21	Shutter Button
7	Status Indicator	22	Continuous Capture Button
8	i Button	23	Fast Video Recording Button
9	Menu Button	24	Power Switch
10	Display Button	25	Mode Dial
11	Playback Button	26	Speaker
12	AF Button/Arrow Button (Up)	27	Tripod Receptacle
13	Flash Button/Arrow Button (Right)	28	Battery Cover Buckle
14	Delete Button/Self-Timer Button/Arrow Button (Down)	29	Battery Cover
15	Macro Button/Arrow Button (Left)		

### 2 Inserting the Battery

1. Open the battery cover.
2. Insert the battery into the battery slot in the correct position as shown in the following diagram.
3. Close the battery cover.

### 3 Setting the Date/Time/Language

1. Push ON/OFF to turn the camera on and the language menu will appear. Use the Up/Down/Left/Right button to select a language, then press **SET** to confirm the language.
2. Use the Up/Down/Left/Right Button again to set the date and time, and press **SET** to confirm.

### 4 Taking a Picture

1. Hold the camera securely.
2. Use the Zoom Lever to select Tele or Wide positions to zoom in or out on your subject.
3. Press the Shutter Button half way to focus on the subject. When the focus box turns green, press the Shutter Button completely down to take the picture.

### 5 Using the mode dial

This camera provides a convenient mode dial that allows you to manually switch between. Different camera settings with ease. Available modes are listed below:

	Auto Mode		Panorama Mode
<b>P</b>	Program AE	<b>SCN</b>	Scene Mode
<b>S</b>	Shutter priority		Movie Mode
<b>M</b>	Manual Mode	<b>CS</b>	Custom Settings
	Face Beautifier		Landscape Mode

### 6 Additional Features

1. Panorama mode: Panorama Mode allows you to create a panoramic picture. The camera will create a panoramic photo by stitching individual images taken in panorama mode.
2. Using quick recording: In shooting mode, press Recording button to begin recording video. When you are finished, press the Recording button again or the Shutter key to stop recording. The camera will store the video and return to shooting mode.

### 7 Using the menu button

To change the settings in each mode, press button, press to move between options, select setting menu, then press **SET** button to select and save menu option.

	Photo Setup		General Setup
	Transmission		File/Software

### 8 Flash Mode

Pop up the flash manually as needed.

### 1 Vues de l'appareil photo

1	Voyant Rayon aide AF / Retardateur	16	Bouton SET
2	Flash	17	Boucles de la sangle
3	Micro	18	Port USB
4	Objectif	19	Port HDMI
5	Ecran LCD	20	Molette du zoom
6	Bouton de correction d'exposition	21	Déclencheur
7	Indicateur d'état	22	Bouton de capture en rafale
8	Bouton I	23	Bouton d'enregistrement vidéo rapide
9	Bouton Menu	24	Curseur d'alimentation
10	Bouton Disp (Affich)	25	Molette de mode.
11	Bouton Lecture	26	Haut-parleur
12	Bouton AF / Bouton Haut	27	Embase pour trépied
13	Bouton Flash / Bouton Droite	28	
14	Bouton Supprimer / Bouton Retardateur / Bouton Bas	29	Couvercle de la batterie
15	Bouton Macro / Bouton Gauche		

### 2 Insérer la batterie

1. Ouvrez le couvercle de la batterie.
2. Placez la batterie dans la fente de la batterie en respectant l'orientation indiquée sur le schéma.
3. Refermez le couvercle de la batterie.

### 3 Régler la date, l'heure et la langue

1. Appuyez sur ON/OFF pour mettre l'appareil en marche. Le menu Langue apparaît, utiliser les boutons gauche/droite, haut/bas pour sélectionner la langue, puis appuyer sur **SET** pour confirmer votre choix.
2. Utiliser à nouveau les boutons gauche/droite, haut/bas pour régler la date et l'heure, appuyer ensuite sur **SET** pour confirmer.

### 4 Prendre une photo

1. Maintenez fermement l'appareil photo.
2. Cadrez votre image sur l'écran LCD.
3. Appuyez sur le bouton déclencheur à la moitié pour faire la mise au point sur l'objet. Quand la case de mise au point devient verte, appuyez complètement sur le bouton déclencheur pour prendre la photo.

### 5 Utilisez le molette Mode

L'appareil photo est doté d'un sélecteur de commande pratique permettant de commuter entre les différents modes avec facilité. Toutes les commandes disponibles sont listées ci-dessous:

	Mode auto		Mode panorama
<b>P</b>	Programme AE	<b>SCN</b>	Mode scène
<b>S</b>	Priorité à la vitesse		Mode film
<b>M</b>	Mode manuel	<b>CS</b>	Réglages personnalisés
	Embellisseur de visage		Mode paysage

### 6 Fonctionnalités supplémentaires

1. Panorama: Le Mode panorama vous permet de créer une image panoramique. L'appareil composera automatiquement une image panoramique avec la prise individuelle que vous faites. Tournez la molette de mode sur le Mode Composition Panorama. Choisissez ensuite entre Composition auto et Composition manuelle à partir du Menu.
2. Utilisation de l'enregistrement vidéo rapide: En mode de prise de vue, appuyez sur le bouton de raccourci Enregistrement pour accéder directement au mode d'enregistrement et enregistrer. Pour terminer l'enregistrement, appuyez sur le bouton de raccourci ou à nouveau sur le déclencheur, vous pouvez ainsi sauvegarder la vidéo et retourner à l'écran de prise de vue.

### 7 Utilisation des touches du menu

Dans chaque mode, vous pouvez activer le menu de réglage, appuyez simplement sur le bouton , appuyez sur pour choisir, sélectionnez pour le menu de réglage, appuyez sur **SET** pour entrer.

	Installation photo		Installation générale
	Transmission		Fichier/logiciel

### 8 Mode flash

Appuyez sur le Bouton ouverture du flash pour sortir le flash.







## Quick Start Guide

クイックスタートガイド  
Panduan ringkas  
คู่มือการเริ่มต้นอย่างรวดเร็ว  
快速指南  
快速入门指南

**Kodak** Licensed Product · ライセンス商品  
Produk Berlisensi · ผลิตภัณฑ์ที่ได้รับอนุญาต  
許可商品 · 许可商品

The Kodak trademark and trade dress are used under license from Kodak.

コダックの商標およびトレードドレスは、コダックのライセンスに基づき使用されます。

Merek dagang dan karakteristik visual dagang Kodak digunakan berdasarkan lisensi dari Kodak.

Kodak และสัญลักษณ์การค้า ถูกใช้ภายใต้การได้รับอนุญาตจาก Kodak

柯達商標及商品外觀皆獲得柯達授權使用。

柯达商标及商品外观都获得柯达授权使用。

© 2013 by JK Imaging Ltd. All rights reserved.

1411 W. 190th Street, Suite 550, Gardena, CA 90248, USA

www.kodakcamera.jkilt.com



CR209081599-0

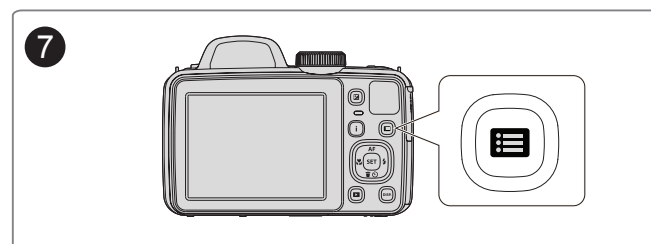
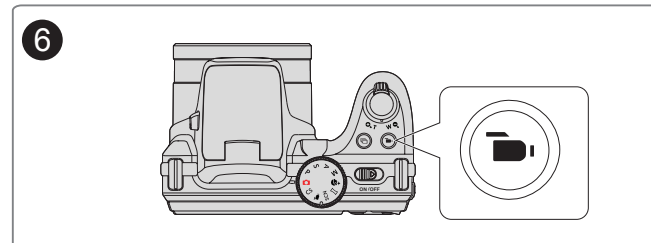
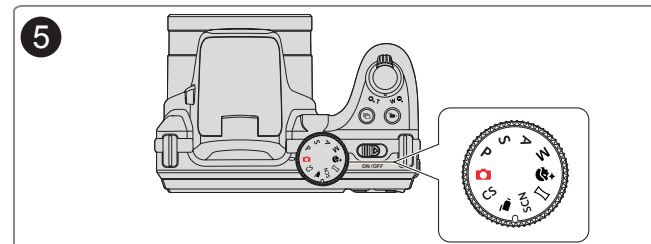
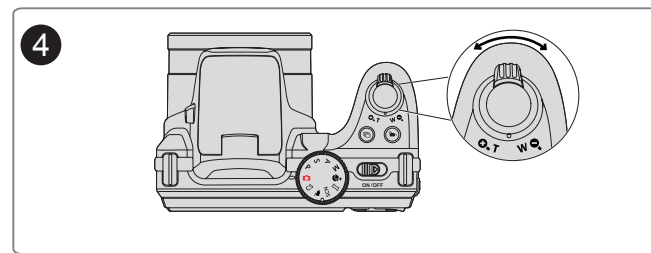
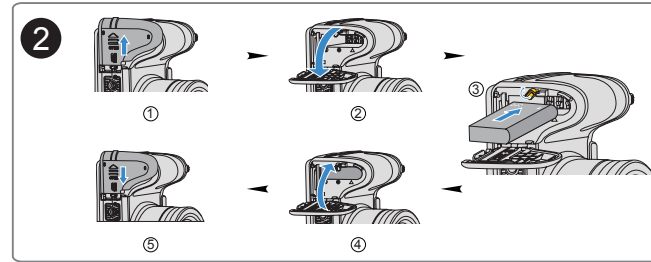
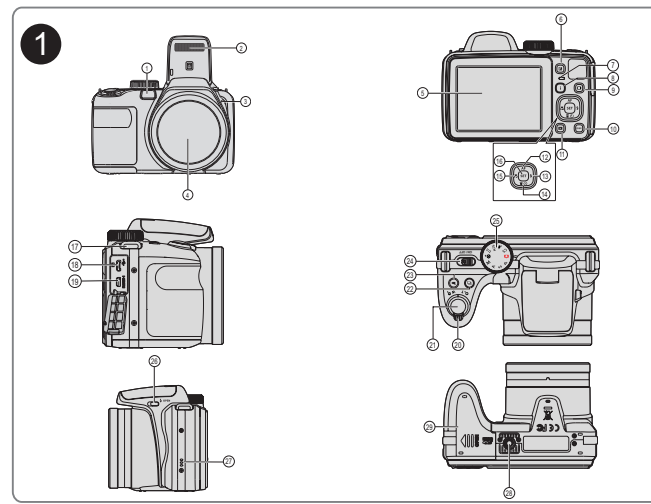

### 1 Camera Views

1	AF Assist Beam/Timer Indicator	16	SET Button
2	Flash Lamp	17	Strap Buckles
3	Microphone	18	USB Port
4	Lens	19	HDMI Port
5	LCD Screen	20	Zoom Lever
6	Exposure Compensation Button	21	Shutter Button
7	Status Indicator	22	Continuous Capture Button
8	i Button	23	Fast Video Recording Button
9	Menu Button	24	Power Switch
10	Display Button	25	Mode Dial
11	Playback Button	26	Flash Button
12	AF Button/Arrow Button (Up)	27	Speaker
13	Flash Button/Arrow Button (Right)	28	Tripod Receptacle
14	Delete Button/Self-Timer Button/Arrow Button (Down)	29	Battery Cover
15	Macro Button/Arrow Button (Left)		

### 2 Inserting the Battery

1. Open the battery cover.
2. Insert the battery into the battery slot in the correct position as shown in the following diagram.
3. Close the battery cover.

### 3 Setting the Date/Time/Language

1. Push ON/OFF to turn the camera on and the language menu will appear. Use the Up/Down/Left/Right button to select a language, then press **SET** to confirm the language.
2. Use the Up/Down/Left/Right Button again to set the date and time, and press **SET** to confirm.

### 4 Taking a Picture

1. Hold the camera securely.
2. Use the Zoom Lever to select Tele or Wide positions to zoom in or out on your subject.
3. Press the Shutter Button half way to focus on the subject. When the focus box turns green, press the Shutter Button completely down to take the picture.

### 5 Using the mode dial

This camera provides a convenient mode dial that allows you to manually switch between. Different camera settings with ease. Available modes are listed below:

	Auto Mode		Face Beautifier
<b>P</b>	Program AE		Panorama Mode
<b>S</b>	Shutter priority	<b>SCN</b>	Scene Mode
<b>A</b>	Aperture priority		Movie Mode
<b>M</b>	Manual Mode	<b>CS</b>	Custom Settings

### 6 Additional Features

1. Panorama mode: Panorama Mode allows you to create a panoramic picture. The camera will create a panoramic photo by stitching individual images taken in panorama mode.
2. Using quick recording: In shooting mode, press Recording button to begin recording video. When you are finished, press the Recording button again or the Shutter key to stop recording. The camera will store the video and return to shooting mode.

### 7 Using the menu button

To change the settings in each mode, press button, press to move between options, select setting menu, then press **SET** button to select and save menu option.

	Photo Setup		General Setup
	Transmission		File/Software

### 8 Flash Mode

Press the flash button to open the flash as needed.

### 1 カメラの外観

1	AFアシストビーム/タイマーインジケータ	16	SET ボタン
2	フラッシュ	17	ストラップ取り付け部
3	マイク	18	USB 端子
4	レンズ	19	HDMI 端子
5	液晶モニター	20	ズームレバー
6	露出補正ボタン	21	シャッターボタン
7	電源ランプ	22	連写ボタン
8	i ボタン	23	動画ボタン
9	Menu ボタン	24	電源スイッチ
10	DISP.ボタン	25	モードダイヤル
11	再生ボタン	26	フラッシュボタン
12	AFモード/機能ボタン上	27	スピーカー
13	フラッシュモード/機能ボタン右	28	三脚ねじ穴
14	消去/セルフタイマー/機能ボタン下	29	電池カバー
15	マクロモード/機能ボタン左		

### 2 電池の挿入

1. バッテリーカバーを開けます。
2. 電池のプラスとマイナスを確認しながら、電池を挿入します。
3. バッテリーカバーを閉めます。

### 3 日時/言語の設定

1. カメラの電源をオンにします。言語メニューが表示されます。機能ボタン上/下、左/右を押して、言語を選択し、**SET** ボタンを押して設定を確認します。
2. 機能ボタン上/下、左/右を押して、日時を設定し、**SET** ボタンを押して設定を確認します。

### 4 撮影の仕方

1. カメラを構えます。液晶モニターで被写体の構図を決めます。
2. ズームレバーを操作して、被写体を拡大するときはT側に回します。広い範囲を撮影するときはW側に回します。
3. シャッターボタンを半分ほど押して、被写体に焦点を合わせます。フォーカスポックスが緑に変わったら、シャッターボタンを完全に下まで押して写真を撮影します。

### 5 モードダイヤルの使用

カメラでは撮影シーンに応じて簡単に切り換えることができるモードダイヤルが付いています。使用可能なモードについて、下記の一覧で説明します:

	自動モード		美肌
<b>P</b>	プログラム AE		パノラマモード
<b>S</b>	シャッター優先	<b>SCN</b>	シーンモード
<b>A</b>	絞り優先		動画モード
<b>M</b>	手動モード	<b>CS</b>	カスタム設定

### 6 優れた機能

1. パノラマでパニング撮影: パノラマモードでは、パノラマ写真を作成します。カメラは撮影した個々の画像で、パノラマ写真を自動的に構成します。
2. 動画撮影ショートカット: 撮影モードで、動画撮影ボタン を押すと、動画モードに切り替わって録画を開始します。動画撮影を終了するには、動画撮影ボタン 、或いはシャッターボタンを押すと、動画を保存して、撮影画面に戻ります。

### 7 メニューボタンを使います

各モードとも、 ボタンを押すと設定メニューが使用可能になります。 ボタンで内容を切り替え、 設定メニューを選択し、**SET** ボタンでメニューに入ります。

	撮影セットアップ		一般的なセットアップ
	転送		ファイル・ソフトウェア

### 8 フラッシュモード

フラッシュポップアップボタン を押して、フラッシュをポップアップさせます。

## 1 Tampilan kamera

1	Indikator Chy Bantuan AF/Timer	16	Tombol SET
2	Lampu Kilat	17	Pengait tali
3	Mikrofon	18	Port USB
4	Lensa	19	Port HDMI
5	Layar LCD	20	Bilah Zoom
6	Tombol Kompensasi Pencahayaan	21	Tombol Rana
7	Indikator Status	22	Tombol pengambilan berkelanjutan
8	Tombol I	23	Tombol Rekam Cepat
9	Tombol Menu	24	Tombol Daya
10	Tombol Layar	25	Mode Putar
11	Tombol Playback	26	Lampu Kilat Tombol
12	Tombol AF/Tombol Panah (Atas)	27	Speaker
13	Tombol Kilat/Tombol Panah (Kanan)	28	Lubang Tripod
14	Tombol Hapus/Tombol Timer Otomatis/Tombol Panah (Bawah)	29	Penutup Baterai
15	Tombol Makro/Tombol Panah (Kiri)		

### 2 Memasukkan baterai

- Buka penutup baterai.
- Pasang baterai ke dalam slot baterai sesuai dengan arah yang benar seperti di diagram.
- Tutup kembali penutup baterai.

### 3 Mengatur Tanggal dan Waktu/Bahasa

- Tekan ON/OFF untuk mengaktifkan kamera, kemudian menu bahasa akan muncul di layar. Gunakan tombol tanda panah Atas/Bawah/Kiri/Kanan untuk memilih bahasa, kemudian tekan tombol **SET** untuk mengkonfirmasikannya.
- Gunakan tombol Atas/Bawah/Kiri/Kanan untuk menetapkan tanggal dan waktu, kemudian tekan tombol **SET** untuk mengkonfirmasikannya.

### 4 Mengambil gambar

- Pegang kamera dengan mantap.
- Atur tampilan foto di layar LCD.
- Tekan separuh Tombol rana untuk fokus pada subjek. Bila kotak fokus menyala hijau, tekan Tombol rana sepenuhnya untuk mengambil gambar.

### 5 Menggunakan tombol mode

Kamera menyediakan mode dial yang nyaman yang memungkinkan Anda untuk dengan mudah beralih di antara berbagai modus. Semua mode yang tersedia tercantum sebagai berikut:

	Mode Otomatis		Percantik Wajah
<b>P</b>	AE Program		Mode Panorama
<b>S</b>	Prioritas rana	<b>SCN</b>	Mode Pemandangan
<b>A</b>	Prioritas Bukaan		Mode Film
<b>M</b>	Mode Manual	<b>CS</b>	Pengaturan Kustom

### 6 Fitur-fitur Unggulan

- Panorama: Mode Panorama dapat digunakan untuk membuat foto panorama. Kamera akan secara otomatis mengomposisikan foto panorama menggunakan pemotretan terpisah yang Anda ambil.
- Menggunakan perekaman cepat: Di mode Pembidikan, tekan tombol pintas Perekaman untuk langsung masuk ke mode perekaman dan melakukan perekaman. Setelah selesai merekam, tekan tombol pintas Perekaman atau tombol Shutter sekali lagi, Anda bisa simpan video dan kembali ke layar pembidikan.

### 7 Menggunakan tombol menu

Di setiap mode, Anda dapat mengaktifkan menu setel, dengan hanya menekan tombol , tekan tombol untuk beralih, pilih menu pengaturan , tekan tombol **SET** untuk masuk.

	Pengaturan Foto		Pengaturan Umum
	Transmisi		File/Perisian

### 8 Mode Lampu Kilat

Tekan tombol kilat untuk memunculkan lampu kilat.

## 1 มุมมองต่างๆ ของกล้อง

1	ลำแสงช่วย AF/สัญลักษณ์แสดงการตั้งเวลา	16	ปุ่ม SET
2	ไฟแฟลช	17	หัวสายรัด
3	ไมโครโฟน	18	พอร์ต USB
4	เลนส์	19	พอร์ต HDMI
5	หน้าจอ LCD	20	แถบชুম
6	ปุ่มชดเชยค่าปริมาณแสง	21	ปุ่มชัตเตอร์
7	ตัวแสดงสถานะ	22	ปุ่มถ่ายภาพต่อเนื่อง
8	ปุ่ม I	23	ปุ่มบันทึกวิดีโออย่างรวดเร็ว
9	ปุ่มเมนู	24	สวิตช์เพาเวอร์
10	ปุ่ม disp	25	ระบบเล่นเพื่อเลือกโหมด
11	ปุ่มเล่น	26	ปุ่มแฟลช
12	ปุ่ม AF/ปุ่มลูกศร (ขึ้น)	27	ลำโพง
13	ปุ่มแฟลช/ปุ่มลูกศร (ขวา)	28	ฐานรองกล้องบนขาตั้ง
14	ปุ่มลบ/ปุ่มตั้งเวลาถ่าย/ปุ่มลูกศร (ลง)	29	ฝาครอบช่องใส่แบตเตอรี่
15	ปุ่ม Macro/ปุ่มลูกศร (ซ้าย)		

### 2 การใส่แบตเตอรี่

- เปิดฝาครอบช่องใส่แบตเตอรี่
- ใส่แบตเตอรี่ลงในช่องแบตเตอรี่ตามที่ด้านขวาที่แสดงในแผนภาพ
- ปิดฝาครอบช่องใส่แบตเตอรี่

### 3 การตั้งค่าวันที่และเวลา/การตั้งค่าภาษา

- กดปุ่ม ON/OFF เพื่อเปิดกล้อง และเมนูภาษาจะปรากฏขึ้น **ไม่**ปุ่ม ขึ้น/ลง/ซ้าย/ขวา เพื่อเลือกภาษา, จากนั้นกดปุ่ม **SET** เพื่อยืนยันภาษา
- ไม่**ปุ่ม ขึ้น/ลง/ซ้าย/ขวา อีกครั้ง เพื่อดังค่าวันที่และเวลา, และกดปุ่ม **SET** เพื่อยืนยัน

### 4 การถ่ายภาพ

- ถือกล้องอย่างมั่นคง.
- กดปุ่มชูมไปทางด้านไว้ด หรือเทลของกล้อง เพื่อชูมเข้าหรือชูมออกบนวัตถุ ในขณะที่ถ่ายภาพ.
- กดปุ่มชัตเตอร์ลงครึ่งทางเพื่อโฟกัสไว้ดดู เมื่อกรอบโฟกัสเป็นสีเขียว กดปุ่มชัตเตอร์ลงจนสุดเพื่อถ่ายภาพ.

### 5 วิธีใช้ระบบเลื่อนโหมด

กล้องถ่ายภาพ จะให้หน้าบັดแสดงโหมดที่สะดวกสบายซึ่งทำให้ท่านสามารถสลับระหว่งโหมดต่างๆ อย่างง่ายดาย โดยมีโหมดต่างๆ ดังนี้:

	โหมดอัตโนมัติ		ตกแต่งใบหน้า
<b>P</b>	โปรแกรม AE		โหมดพาโนรามา
<b>S</b>	ชัตเตอร์สำคัญ	<b>SCN</b>	โหมดภาพ
<b>A</b>	ความเร็วชัตเตอร์อัตโนมัติ		โหมดภาพยนตร์
<b>M</b>	โหมดแมนนวล	<b>CS</b>	การตั้งค่าแบบกำหนดเอง

### 6 คุณลักษณะสื่พีเรีย

- พาโนรามา: โหมดพาโนรามา อนุญาตให้คุณสร้างภาพแบบพาโนรามา กล้องจะสร้างภาพ พาโนรามา
- วิธีใช้การบันทึกอย่างรวดเร็ว: ในโหมดถ่ายภาพ กดปุ่มลัดสำหรับบันทึก เพื่อเข้าสู่สถานะการบันทึกโดยตรงและทำการบันทึกหลังจากสิ้นสุดการบันทึก ให้กดปุ่มลัดหรือปุ่มชัตเตอร์อีกครั้งคุณสามารถบันทึกวิดีโอและกลับไปยังหน้าจอถ่ายภาพได้

### 7 การใช้ปุ่มเมนู

ในแต่ละโหมด คุณสามารถเปิดใช้งานเมนูตั้งค่า เพียงกดปุ่ม และกดปุ่ม เพื่อเลือก เลือกเมนูการตั้งค่า จากนั้นกด ปุ่ม **SET** เพื่อ เข้าไป

	ตั้งค่ารูปภาพ		ตั้งค่าทั่วไป
	ส่ง		ไฟล์/ซอฟต์แวร์

### 8 โหมดแฟลช

กดปุ่มแฟลช เพื่อเปิดไฟแฟลช

## 1 相機各面視圖

1	自動對焦輔助燈/計時器指示燈	16	確定按鈕
2	閃光燈	17	背帶扣
3	麥克風	18	USB連接埠
4	鏡頭	19	HDMI連接埠
5	LCD螢幕	20	變焦桿
6	曝光補償按鈕	21	快門按鈕
7	狀態顯示燈	22	連拍按鈕
8	i按鈕	23	快速錄影按鈕
9	選單按鈕	24	電源開關
10	DISP按鈕	25	模式盤
11	回放按鈕	26	閃光燈按鈕
12	AF按鈕/方向按鈕（上）	27	揚聲器
13	閃光燈按鈕/方向按鈕（右）	28	三腳架固定孔
14	刪除按鈕/自拍按鈕/方向按鈕（下）	29	電池蓋
15	近拍按鈕/方向按鈕（左）		

### 2 插入電池

- 開啟電池蓋。
- 將電池依圖示方向正確裝入電池槽中。
- 關上電池蓋。

### 3 設定日期/時間/語言

- 推動 ON/OFF 將相機開機，LCD將顯示語言設定選單。使用向上/向下/向左/向右按鈕選擇語言，然後按 **SET** 確認語言。
- 使用向上/向下/向左/向右按鈕設置日期和時間，然後按 **SET** 確認。

### 4 拍照

- 握緊相機。
- 將變焦桿切換至相機的望遠端（T）或廣角端（W）位置，即可放大或縮小您欲拍攝的對象。
- 輕按快門按鈕將焦距對準拍攝物體中央。當LCD出現綠色對焦框時，完全按下快門拍攝照片。

### 5 使用模式盤

相機提供一個方便的模式盤，可讓您輕鬆切換各個模式。以下列出所有可選擇的模式:

	自動模式		美顏效果
<b>P</b>	程序自動曝光		全景模式
<b>S</b>	快門先決	<b>SCN</b>	場景模式
<b>A</b>	光圈先決		錄影模式
<b>M</b>	手動模式	<b>CS</b>	使用者自定義

### 6 特色功能說明

- 全景合成模式：您可利用自動全景合成模式來拍攝超廣角的全景照片，相機會自動將您所拍攝照片合成一張全景照片。
- 使用快速錄影：在拍攝模式下，按壓錄影快捷按鈕 ，畫面將直接進入錄影狀態並進行錄影。錄影完成後，再按壓錄影快捷按鈕或快門按鈕，即可存儲動畫，并返回到拍攝畫面。

### 7 使用菜單按鈕

在所有模式中均可開啟設定選單，只要按下 鍵，按壓 按鈕切換，選擇 設定選單，按 **SET** 進入。

	相片設定		基本設定
	連接設定		檔案與軟體設定

### 8 閃光燈模式顯示

按壓閃光燈彈起 按鈕，閃光燈即可彈起。

## 1 相机概览

1	自动对焦辅助灯/计时器指示灯	16	确定按钮
2	闪光灯	17	背带扣
3	麦克风	18	USB连接埠
4	镜头	19	HDMI连接埠
5	LCD荧幕	20	变焦杆
6	曝光补偿按钮	21	快门按钮
7	状态显示灯	22	连拍按钮
8	i按钮	23	快速錄影按钮
9	选单按钮	24	电源开关
10	DISP按钮	25	模式盘
11	回放按钮	26	闪光灯按钮
12	AF按钮/方向按钮（上）	27	扬声器
13	闪光灯按钮/方向按钮（右）	28	三脚架固定孔
14	删除按钮/自拍按钮/方向按钮（下）	29	电池盖
15	近拍按钮/方向按钮（左）		

### 2 装入电池

- 打开电池盖。
- 将电池依图示方向正确装入电池槽中。
- 关上电池盖。

### 3 设置日期/时间/语言

- 推动 ON/OFF 打开相机，LCD上会出现语言设定选单。使用上下左右按钮选择一个语言，然后按 **SET** 确认语言。
- 使用上下左右按钮设置日期和时间，然后按 **SET** 确认。

### 4 拍照

- 牢牢握住相机。
- 将变焦杆切换至相机的远摄位置（T）或广角位置（W），即可放大或缩小您要拍摄的对象。
- 半按快门按钮进行对焦，当LCD出现绿色对焦框时，完全按下快门拍照。

### 5 使用模式盘

相机提供一个方便的模式盘，可让您轻松切换各个模式。以下列出所有可选择的模式:

	自动模式		脸部美肤
<b>P</b>	AE程序		全景模式
<b>S</b>	快门优先级	<b>SCN</b>	场景模式
<b>A</b>	光圈优先		錄影模式
<b>M</b>	手动模式	<b>CS</b>	用户自定义

### 6 特色功能说明

- 全景合成模式：您可利用自动全景合成模式来拍摄超广角的全景照片，相机会自动将您所拍摄照片合成一张全景照片。
- 使用快速录影：在拍摄模式下，按压录影快捷按钮 ，画面将直接进入录影状态并进行录影。录影完成后，再按录影快捷按钮或快门按钮，即可存储动画，并返回到拍摄動畫画面。

### 7 使用菜单按钮

在所有模式中均可开启设定选单，只要按下 键，按压 按钮切换，选择 设定选单，按 **SET** 进入。

	相片设置		一般设置
	传输		文件/软件

### 8 闪关灯模式显示

按压闪光灯弹起 按钮，闪光灯即可弹起。





## Quick Start Guide

Snabbstartsguide  
Introduktionsvejledning  
Pikaopas  
Hurtigstartveiledning  
Snelstartgids

**Kodak** Licensed Product • Licensierad produkt  
Licenseret produkt • Lisensoitu tuote  
Lisensiert produkt • Product onder licentie

The Kodak trademark and trade dress are used under license from Kodak.

Kodaks varumärke och varumärkesskylt används under licens från Kodak.

Kodak varemærket og varedesignet bruges med licens fra Kodak.

Kodak-tavaramerkkiä ja Kodak-ilmiasua käytetään Kodakin lisenssin alaisuudessa.

Kodaks varemerke og kjennetegn brukes under licens fra Kodak.

Het Kodak-handelsmerk en de Kodak-handelskenmerken worden gebruikt onder licentie van Kodak.

© 2013 by JK Imaging Ltd. All rights reserved.

1411 W. 190th Street, Suite 550, Gardena, CA 90248, USA

www.kodakcamera.jkilt.com



CR209081499-0

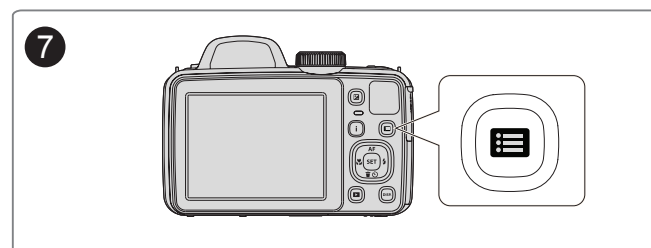
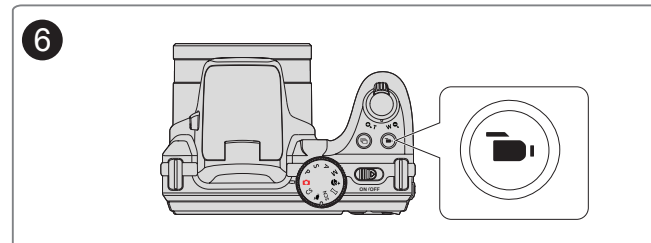
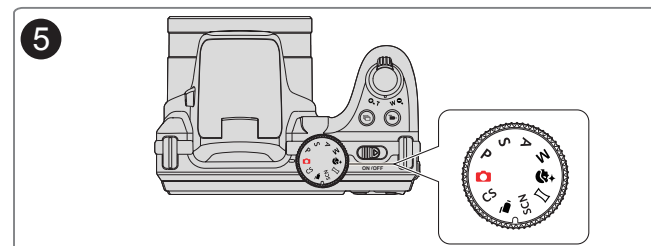
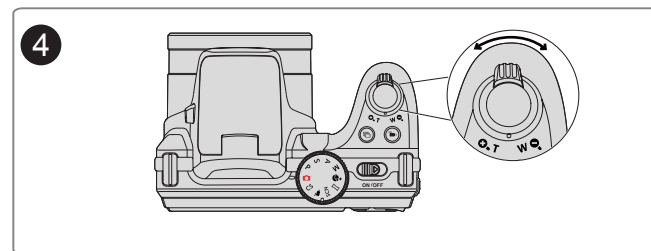
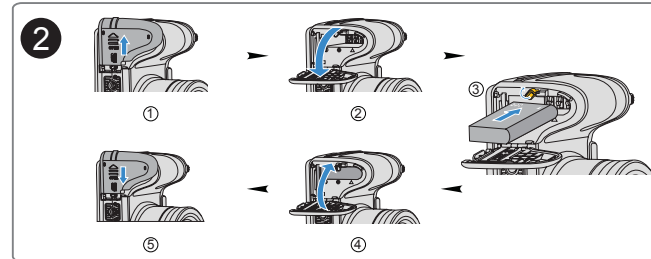
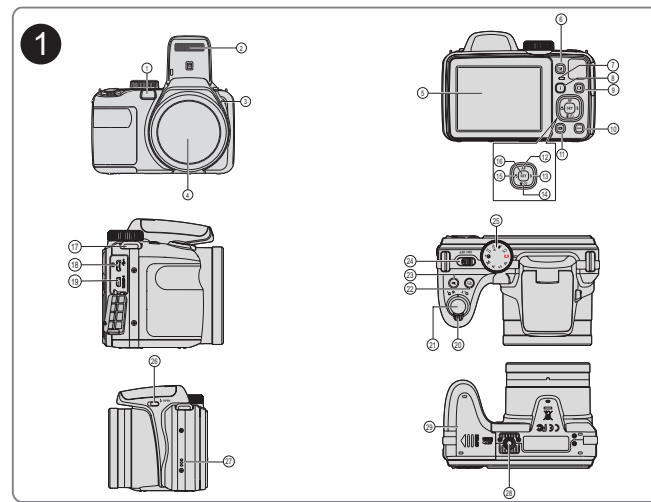

### 1 Camera Views

1	AF Assist Beam/Timer Indicator	16	SET Button
2	Flash Lamp	17	Strap Buckles
3	Microphone	18	USB Port
4	Lens	19	HDMI Port
5	LCD Screen	20	Zoom Lever
6	Exposure Compensation Button	21	Shutter Button
7	Status Indicator	22	Continuous Capture Button
8	i Button	23	Fast Video Recording Button
9	Menu Button	24	Power Switch
10	Display Button	25	Mode Dial
11	Playback Button	26	Flash Button
12	AF Button/Arrow Button (Up)	27	Speaker
13	Flash Button/Arrow Button (Right)	28	Tripod Receptacle
14	Delete Button/Self-Timer Button/Arrow Button (Down)	29	Battery Cover
15	Macro Button/Arrow Button (Left)		

### 2 Inserting the Battery

1. Open the battery cover.
2. Insert the battery into the battery slot in the correct position as shown in the following diagram.
3. Close the battery cover.

### 3 Setting the Date/Time/Language

1. Push ON/OFF to turn the camera on and the language menu will appear. Use the Up/Down/Left/Right button to select a language, then press **SET** to confirm the language.
2. Use the Up/Down/Left/Right Button again to set the date and time, and press **SET** to confirm.

### 4 Taking a Picture

1. Hold the camera securely.
2. Use the Zoom Lever to select Tele or Wide positions to zoom in or out on your subject.
3. Press the Shutter Button half way to focus on the subject. When the focus box turns green, press the Shutter Button completely down to take the picture.

### 5 Using the mode dial

This camera provides a convenient mode dial that allows you to manually switch between. Different camera settings with ease. Available modes are listed below:

	Auto Mode		Face Beautifier
<b>P</b>	Program AE		Panorama Mode
<b>S</b>	Shutter priority	<b>SCN</b>	Scene Mode
<b>A</b>	Aperture priority		Movie Mode
<b>M</b>	Manual Mode	<b>CS</b>	Custom Settings

### 6 Additional Features

1. Panorama mode: Panorama Mode allows you to create a panoramic picture. The camera will create a panoramic photo by stitching individual images taken in panorama mode.
2. Using quick recording: In shooting mode, press Recording button to begin recording video. When you are finished, press the Recording button again or the Shutter key to stop recording. The camera will store the video and return to shooting mode.

### 7 Using the menu button

To change the settings in each mode, press button, press to move between options, select setting menu, then press **SET** button to select and save menu option.

	Photo Setup		General Setup
	Transmission		File/Software

### 8 Flash Mode

Press the flash button to open the flash as needed.

### 1 Kamerans delar

1	AF hjälpljus/Timerindikator	16	SET-knapp
2	Blixtlampa	17	Bandspänne
3	Mikrofon	18	USB-port
4	Objektiv	19	HDMI-port
5	LCD-skärm	20	Zoomreglage
6	Knapp för exponeringskompensering	21	Slutarknapp
7	Statusindikator	22	Fånga kontinuerlig knappen
8	I-knapp	23	Snabbvideoinspelingsknapp
9	Menyknapp	24	Strömbrytare
10	visn.knapp	25	Lägesvalsknappen
11	Uppspelningsknapp	26	Blixtlampa-knapp
12	AF-knapp/Pilknapp (upp)	27	Högtalare
13	Blixtknapp/Pilknapp (höger)	28	Stativfäste
14	Radera-knapp/Självtlösar-knapp/Pilknapp (ner)	29	Batterilock
15	Makro-knapp/Pilknapp (vänster)		

### 2 Sätt i batteriet

1. Öppna batterilocket.
2. Placera batteriet i batterifacket enligt rätt riktning som visas på ritningen.
3. Stäng batterilocket.

### 3 Använda lägesvalsknappen

1. Tryck på ON/OFF för att slå på kameran. Språkmenyn visas. Välj språk med hjälp av upp/ned/vänster/höger. Tryck sedan på **SET** för att bekräfta språket.
2. Ställ in tid och datum med hjälp av upp/ned/vänster/höger. Tryck sedan på **SET** för att bekräfta.

### 4 Ta en bild

1. Håll or dentligt i kameran.
2. Komponera bilden på LCD-skärmen.
3. Tryck ned avtryckaren halvvägs för att fokusera på objektet. När fokusrutan blir grön tryck ned avtryckaren helt för att ta bilden.

### 5 Använda lägesomkopplaren

Kameramodellen har en praktisk lägesvalsknapp som du kan använda för att enkelt växla mellan olika lägen. Följande lägen är tillgängliga:

	Auto-läge		Ansiktsförbättrare
<b>P</b>	Program-AE		Panoramaläge
<b>S</b>	Slutarprioritet	<b>SCN</b>	Scenläge
<b>A</b>	Bländarförval		Filmäge
<b>M</b>	Manuellt läge	<b>CS</b>	Anpassade inställningar

### 6 Extra funktioner

1. Panorama: I panoramaläget kan du skapa en panoramabild. Kameran komponerar automatiskt en panoramabild av de individuella bilderna du tar.
2. Använd snabbinspelning: Tryck på genvägsknappen för inspelning i bildtagningsläget för att gå in i inspelningsläget direkt och börja spela in. När du är klar med inspelningen, tryck på genvägsknappen för inspelningen eller på avtryckarknappen igen, så kan du spara videon och gå tillbaka till bildskärmen.

### 7 Använda menyknappen

I varje läge kan du aktivera inställd meny, tryck bara på knappen, tryck knappen för att växla, välj inställningsmenyn, tryck **SET** knappen för att öppna.

	Fotoinställning		Allmänna inställningar
	Överföring		Fil/Mjukvara

### 8 Blixtläge

Tryck på Blixtuppfällning-knapp för att blixten ska komma fram.







## Quick Start Guide

Kolay Kullanım Kılavuzu  
Průvodce rychlého spuštění  
Gyors indúlás menü  
Instrukcja szybkiego uruchomienia  
Краткое руководство

**Kodak** Licensed Product • Lisanslı ürün  
Licencovaný produkt • Engedélyezett termék  
Produkt z licencją • Лицензированный продукт

The Kodak trademark and trade dress are used under license from Kodak.

Kodak ticari markası ve trade dress Kodak'ın lisansı altında kullanılmaktadır.

Ochranná známka a obchodní podoba Kodak jsou používány na základě licence společnosti Kodak.

A Kodak márkajelzés és kereskedelmi jelzés használatára a Kodak engedélyével történt.

Znak towarowy i wzornictwo Kodak są używane na podstawie licencji Kodak.

Товарный знак Kodak и товарная упаковка используются по лицензии компании Kodak.

© 2013 by JK Imaging Ltd. All rights reserved.

1411 W. 190th Street, Suite 550, Gardena, CA 90248, USA

www.kodakcamera.jkilt.com



CR209082899-0

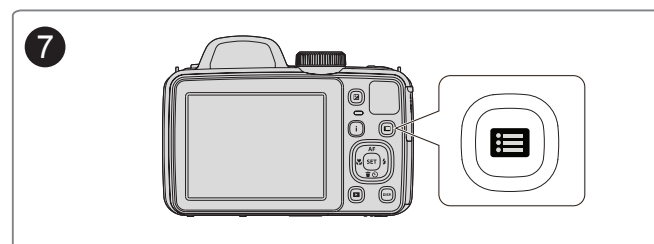
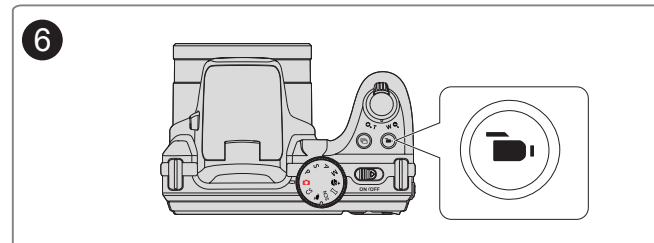
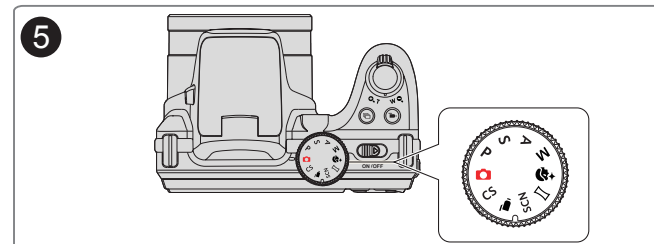
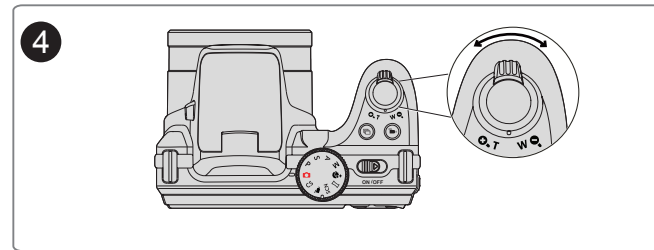
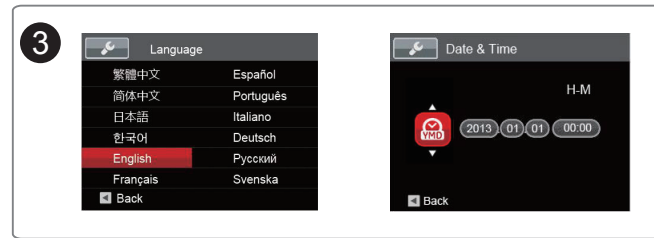
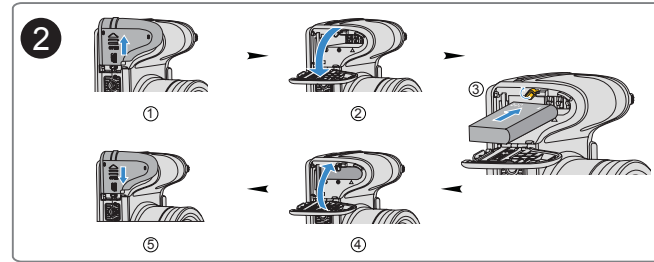
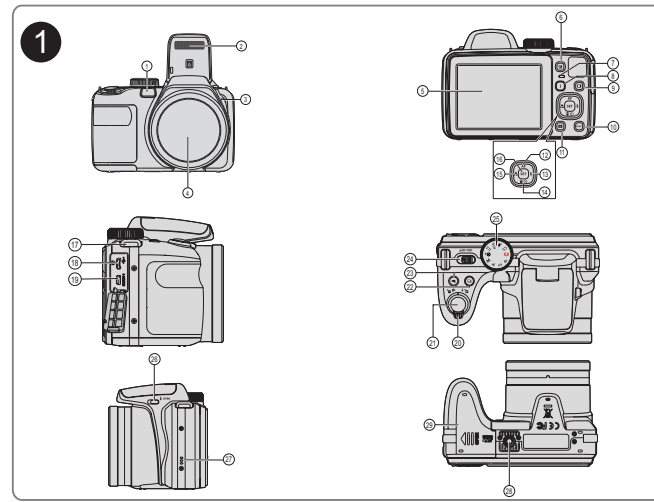

### 1 Camera Views

1	AF Assist Beam/Timer Indicator	16	SET Button
2	Flash Lamp	17	Strap Buckles
3	Microphone	18	USB Port
4	Lens	19	HDMI Port
5	LCD Screen	20	Zoom Lever
6	Exposure Compensation Button	21	Shutter Button
7	Status Indicator	22	Continuous Capture Button
8	i Button	23	Fast Video Recording Button
9	Menu Button	24	Power Switch
10	Display Button	25	Mode Dial
11	Playback Button	26	Flash Button
12	AF Button/Arrow Button (Up)	27	Speaker
13	Flash Button/Arrow Button (Right)	28	Tripod Receptacle
14	Delete Button/Self-Timer Button/Arrow Button (Down)	29	Battery Cover
15	Macro Button/Arrow Button (Left)		

### 2 Inserting the Battery

1. Open the battery cover.
2. Insert the battery into the battery slot in the correct position as shown in the following diagram.
3. Close the battery cover.

### 3 Setting the Date/Time/Language

1. Push ON/OFF to turn the camera on and the language menu will appear. Use the Up/Down/Left/Right button to select a language, then press **SET** to confirm the language.
2. Use the Up/Down/Left/Right Button again to set the date and time, and press **SET** to confirm.

### 4 Taking a Picture

1. Hold the camera securely.
2. Use the Zoom Lever to select Tele or Wide positions to zoom in or out on your subject.
3. Press the Shutter Button half way to focus on the subject. When the focus box turns green, press the Shutter Button completely down to take the picture.

### 5 Using the mode dial

This camera provides a convenient mode dial that allows you to manually switch between. Different camera settings with ease. Available modes are listed below:

	Auto Mode		Face Beautifier
<b>P</b>	Program AE		Panorama Mode
<b>S</b>	Shutter priority	<b>SCN</b>	Scene Mode
<b>A</b>	Aperture priority		Movie Mode
<b>M</b>	Manual Mode	<b>CS</b>	Custom Settings

### 6 Additional Features

1. Panorama mode: Panorama Mode allows you to create a panoramic picture. The camera will create a panoramic photo by stitching individual images taken in panorama mode.
2. Using quick recording: In shooting mode, press Recording button to begin recording video. When you are finished, press the Recording button again or the Shutter key to stop recording. The camera will store the video and return to shooting mode.

### 7 Using the menu button

To change the settings in each mode, press button, press to move between options, select setting menu, then press **SET** button to select and save menu option.

	Photo Setup		General Setup
	Transmission		File/Software

### 8 Flash Mode

Press the flash button to OPEN open the flash as needed.

### 1 Kamera Görünümü

1	AF yardımcı ışık/Zamanlayıcı Göstergesi	16	SET Düğmesi
2	Flaş Lambası	17	Kayış tokaları
3	Mikrofon	18	USB Portu
4	Objektif	19	HDMI Portu
5	LCD Ekran	20	Yakınlaştırma Çubuğu
6	Poz Dengeleme Düğmesi	21	Deklanşör
7	Durum Göstergesi	22	Sürekli çekim düğmesi
8	I Düğmesi	23	Hızlı Video Kayıt Düğmesi
9	Menü Düğmesi	24	Güç Anahtarı
10	Ekran Düğmesi	25	Mod Kadranı
11	Oynatma Düğmesi	26	Flaş Düğmesi
12	AF Düğmesi/Ok Düğmesi (Yukarı)	27	Hoparlör
13	Flaş Düğmesi/Ok Düğmesi (Sağ)	28	Tripod Girişi
14	Sil Düğmesi/Zamanlayıcı Düğmesi/Ok Düğmesi (Aşağı)	29	Pil Kapağı
15	Makro Düğmesi/Ok Düğmesi (Sol)		

### 2 Pili yerleştirme

1. Pil kapağını açın.
2. Şekilde gösterilen doğru yöne göre pili, pil yuvasına yerleştirin.
3. Pil kapağını kapatın.

### 3 Tarih/Saat/Dilin Ayarlanması

1. Aç/Kapa düğmesine basarak fotoğraf makinenizi açınız, dil menüsü ekranda çıkacaktır. Bir dil seçmek için Yukarı/Aşağı/Sol/Sağ tuşlarını kullanın, ve dili doğrulamak için tamam **SET** düğmesine basın.
2. Tarih ve saati ayarlamak için Yukarı/Aşağı/Sol/Sağ tuşlarını kullanın ve doğrulamak için **SET** tamam düğmesine basın.

### 4 Resim çekmek

1. Kamerayı sıkıca tutun.
2. Resminizi LCD ekranda düzenleyin.
3. Özneye odaklamak için Deklanşör düğmesine yarım basın. Odaklama kutusu yeşile döndüğünde, fotoğraf çekmek için Deklanşör düğmesine sonuna kadar basın.

### 5 Mod Kadranının Kullanımı

Fotoğraf Makinesi modlar arasında kolaylıkla geçiş yapmanızı sağlayan kullanışlı bir mod kadranına sahiptir. Kullanılabilecek modlar aşağıda listelenmiştir:

	Oto Modu		Yüz Güzelleştirici
<b>P</b>	Program AE		Panoramik Mod
<b>S</b>	Deklanşör Önceliği	<b>SCN</b>	Sahne Modu
<b>A</b>	Diyafram öncelikli pozlama		Film Modu
<b>M</b>	Manuel Mod	<b>CS</b>	Özel Ayarlar

### 6 Üstün Özellikler

1. Panorama: Panorama modu panoramik bir resim yaratmanızı sağlar. Kamera panoramik bir resim oluşturur.
2. Hızlı kayıtlı kullanma: Çekim modunda, Kayıt durumuna doğrudan geçmek ve kayıt yapmak için Kayıt kısayol tuşuna basın. Kaydı bitirdikten sonra, Kayıt kısayol tuşuna ya da Deklanşör tuşuna tekrar basın, videoyu kaydeder ve çekim ekranına dönersiniz.

### 7 Menü tuşunun kullanımı

Her modda, ayar menüsünü etkinleştirebilirsiniz, düğmesine basın, geçiş yapmak için düğmesine basın, ayar menüsünü seçin, girmek için **SET** düğmesine basın.

	Resim Ayarları		Genel Ayarlar
	İletim		Dosya/Yazılım

### 8 Flaş Modu

Flaş ışığını açmak için flaş açma düğmesi OPEN düğmesine basın.







## Quick Start Guide

Guide de Mise en route

Quick Start Guide(印地語)

Quick Start Guide(阿拉伯)

**Kodak** Licensed Product • Produit Autorisé  
Licensed Product(印地語) • Licensed  
Product(阿拉伯)

The Kodak trademark and trade dress are used under license from Kodak.

La marque de commerce Kodak et son apparence sont utilisées sous licence Kodak.

The Kodak trademark and trade dress are used under license from Kodak.(印地語)

The Kodak trademark and trade dress are used under license from Kodak.(阿拉伯語)

© 2013 by JK Imaging Ltd. All rights reserved.

1411 W. 190th Street, Suite 550, Gardena, CA 90248, USA

www.kodakcamera.jkilt.com



CR209082999-0

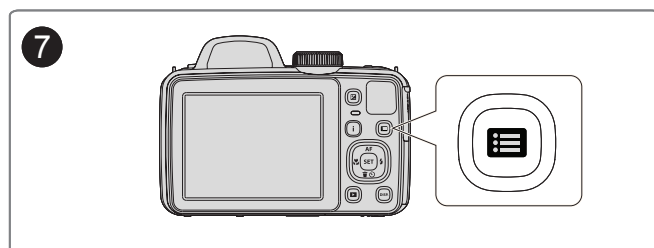
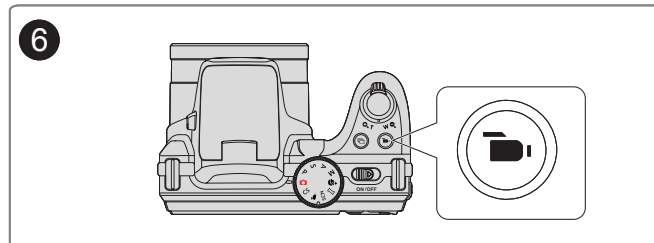
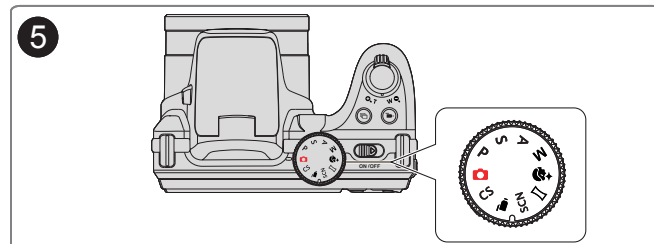
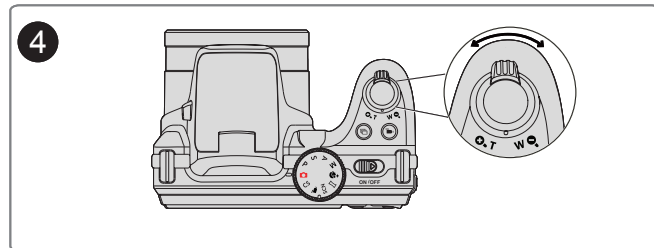
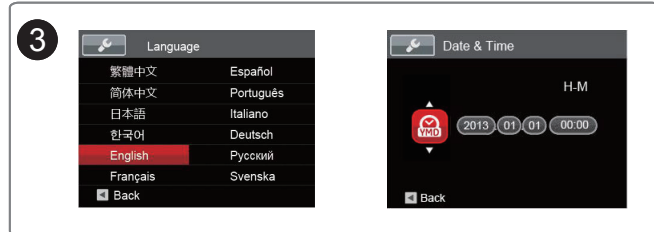
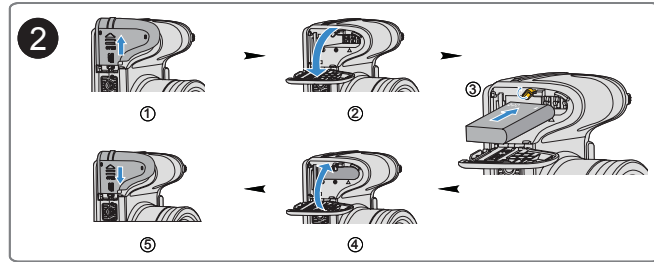
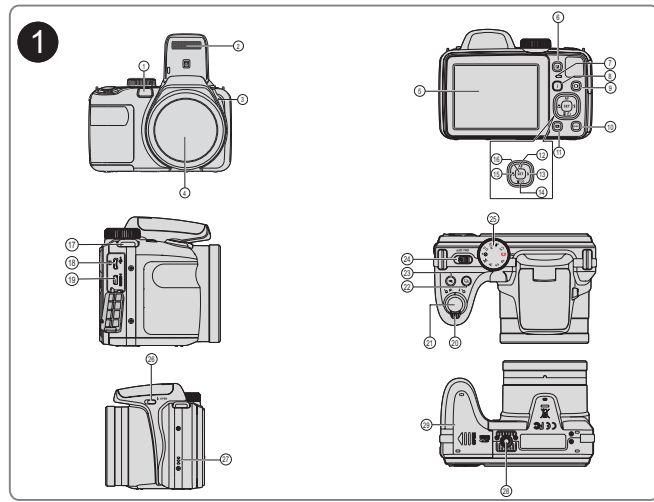

### 1 Camera Views

1	AF Assist Beam/Timer Indicator	16	SET Button
2	Flash Lamp	17	Strap Buckles
3	Microphone	18	USB Port
4	Lens	19	HDMI Port
5	LCD Screen	20	Zoom Lever
6	Exposure Compensation Button	21	Shutter Button
7	Status Indicator	22	Continuous Capture Button
8	i Button	23	Fast Video Recording Button
9	Menu Button	24	Power Switch
10	Display Button	25	Mode Dial
11	Playback Button	26	Flash Button
12	AF Button/Arrow Button (Up)	27	Speaker
13	Flash Button/Arrow Button (Right)	28	Tripod Receptacle
14	Delete Button/Self-Timer Button/Arrow Button (Down)	29	Battery Cover
15	Macro Button/Arrow Button (Left)		

### 2 Inserting the Battery

- Open the battery cover.
- Insert the battery into the battery slot in the correct position as shown in the following diagram.
- Close the battery cover.

### 3 Setting the Date/Time/Language

- Push ON/OFF to turn the camera on and the language menu will appear. Use the Up/Down/Left/Right button to select a language, then press **SET** to confirm the language.
- Use the Up/Down/Left/Right Button again to set the date and time, and press **SET** to confirm.

### 4 Taking a Picture

- Hold the camera securely.
- Use the Zoom Lever to select Tele or Wide positions to zoom in or out on your subject.
- Press the Shutter Button half way to focus on the subject. When the focus box turns green, press the Shutter Button completely down to take the picture.

### 5 Using the mode dial

This camera provides a convenient mode dial that allows you to manually switch between. Different camera settings with ease. Available modes are listed below:

<b>AUTO</b> Auto Mode	<b>FACE</b> Face Beautifier
<b>P</b> Program AE	<b>PAN</b> Panorama Mode
<b>S</b> Shutter priority	<b>SCN</b> Scene Mode
<b>A</b> Aperture priority	<b>MOV</b> Movie Mode
<b>M</b> Manual Mode	<b>CS</b> Custom Settings

### 6 Additional Features

- Panorama mode: Panorama Mode allows you to create a panoramic picture. The camera will create a panoramic photo by stitching individual images taken in panorama mode.
- Using quick recording: In shooting mode, press Recording button to begin recording video. When you are finished, press the Recording button again or the Shutter key to stop recording. The camera will store the video and return to shooting mode.

### 7 Using the menu button

To change the settings in each mode, press **MENU** button, press **▲▼** to move between options, select **SETTING** setting menu, then press **SET** button to select and save menu option.

Photo Setup	General Setup
Transmission	File/Software

### 8 Flash Mode

Press the flash button to open the flash as needed.

### 1 Vues de l'appareil photo

1	Voyant Rayon aide AF / Retardateur	16	Bouton SET
2	Flash	17	Boucles de la sangle
3	Micro	18	Port USB
4	Objectif	19	Port HDMI
5	Ecran LCD	20	Molette du zoom
6	Bouton de correction d'exposition	21	Déclencheur
7	Indicateur d'état	22	Bouton de capture en rafale
8	Bouton I	23	Bouton d'enregistrement vidéo rapide
9	Bouton Menu	24	Curseur d'alimentation
10	Bouton Disp (Affich)	25	Molette de mode.
11	Bouton Lecture	26	Bouton Flash
12	Bouton AF / Bouton Haut	27	Haut-parleur
13	Bouton Flash / Bouton Droite	28	Embase pour trépied
14	Bouton Supprimer / Bouton Retardateur / Bouton Bas	29	Couvercle de la batterie
15	Bouton Macro / Bouton Gauche		

### 2 Insérer la batterie

- Ouvrez le couvercle de la batterie.
- Placez la batterie dans la fente de la batterie en respectant l'orientation indiquée sur le schéma.
- Refermez le couvercle de la batterie.

### 3 Régler la date, l'heure et la langue

- Appuyez sur ON/OFF pour mettre l'appareil en marche. Le menu Langue apparaît, utiliser les boutons gauche/droite, haut/bas pour sélectionner la langue, puis appuyer sur **SET** pour confirmer votre choix.
- Utiliser à nouveau les boutons gauche/droite, haut/bas pour régler la date et l'heure, appuyer ensuite sur **SET** pour confirmer.

### 4 Prendre une photo

- Maintenez fermement l'appareil photo.
- Cadrez votre image sur l'écran LCD.
- Appuyez sur le bouton déclencheur à la moitié pour faire la mise au point sur l'objet. Quand la case de mise au point devient verte, appuyez complètement sur le bouton déclencheur pour prendre la photo.

### 5 Utilisez le molette Mode

L'appareil photo est doté d'un sélecteur de commande pratique permettant de commuter entre les différents modes avec facilité. Toutes les commandes disponibles sont listées ci-dessous:

Mode auto	Embellisseur de visage
<b>P</b> Programme AE	Mode panorama
<b>S</b> Priorité à la vitesse	<b>SCN</b> Mode scène
<b>A</b> Priorité à l'ouverture du diaphragme	Mode film
<b>M</b> Mode manuel	<b>CS</b> Réglages personnalisés

### 6 Fonctionnalités supplémentaires

- Panorama: Le Mode panorama vous permet de créer une image panoramique. L'appareil composera automatiquement une image panoramique avec la prise individuelle que vous faites. Tournez la molette de mode sur le Mode Composition Panorama. Choisissez ensuite entre Composition auto et Composition manuelle à partir du Menu.
- Utilisation de l'enregistrement vidéo rapide: En mode de prise de vue, appuyez sur le bouton de raccourci Enregistrement pour accéder directement au mode d'enregistrement et enregistrer. Pour terminer l'enregistrement, appuyez sur le bouton de raccourci ou à nouveau sur le déclencheur, vous pouvez ainsi sauvegarder la vidéo et retourner à l'écran de prise de vue.

### 7 Utilisation des touches du menu

Dans chaque mode, vous pouvez activer le menu de réglage, appuyez simplement sur le bouton **MENU**, appuyez sur **▲▼** pour choisir, sélectionnez **SETTING** pour le menu de réglage, appuyez sur **SET** pour entrer.

Installation photo	Installation générale
Transmission	Fichier/logiciel

### 8 Mode flash

Appuyez sur le Bouton ouverture du flash pour sortir le flash.



## 1 Camera Views

1	AF Assist Beam/Timer Indicator	16	SET Button
2	Flash Lamp	17	Strap Buckles
3	Microphone	18	USB Port
4	Lens	19	HDMI Port
5	LCD Screen	20	Zoom Wheel
6	Exposure Compensation Button	21	Shutter Button
7	Status Indicator	22	Continuous Capture Button
8	i Button	23	Fast Video Recording Button
9	Menu Button	24	Power Switch
10	Display Button	25	Mode Dial
11	Playback Button	26	Flash Button
12	AF Button/Arrow Button (Up)	27	Speaker
13	Flash Button/Arrow Button (Right)	28	Tripod Receptacle
14	Delete Button/Self-Timer Button/Arrow Button (Down)	29	Battery Cover
15	Macro Button/Arrow Button (Left)		

## 2 Inserting the Battery

1. Open the battery cover.
2. Insert the battery into the battery slot in the correct position as shown in the following diagram.
3. Close the battery cover.

## 3 Setting the Date/Time/Language





1. Push ON/OFF to turn the camera on and the language menu will appear. Use the Up/Down/Left/Right button to select a language, then press  to confirm the language.
2. Use the Up/Down/Left/Right Button again to set the date and time, and press  to confirm.

## 4 Taking a Picture

1. Hold the camera securely.
2. Use the zoom toggle Wheel to select Tele or Wide positions to zoom in or out on your subject.
3. Press the Shutter Button half way to focus on the subject. When the focus box turns green, press the Shutter Button completely down to take the picture.

## 5 Using the mode dial





This camera provides a convenient mode dial that allows you to manually switch between. Different camera settings with ease. Available modes are listed below:





	Auto Mode		Face Beautifier
<b>P</b>	Program AE		Panorama Mode
<b>S</b>	Shutter priority	<b>SCN</b>	Scene Mode
<b>A</b>	Aperture priority		Movie Mode
<b>M</b>	Manual Mode	<b>CS</b>	Custom Settings

## 6 Additional Features

1. Panorama mode: Panorama Mode allows you to create a panoramic picture. The camera will create a panoramic photo by stitching individual images taken in panorama mode.
2. Using quick recording: In shooting mode, press Recording button  to begin recording video. When you are finished, press the Recording button again or the Shutter key to stop recording. The camera will store the video and return to shooting mode.

## 7 Using the menu button

To change the settings in each mode, press  button, press  to move between options, select  setting menu, then press  button to select and save menu option.

	Photo Setup		General Setup
	Transmission		File/Software

## 8 Flash Mode

Press the flash button  to open the flash as needed.



## 1 Camera Views

1	AF Assist Beam/Timer Indicator	16	SET Button
2	Flash Lamp	17	Strap Buckles
3	Microphone	18	USB Port
4	Lens	19	HDMI Port
5	LCD Screen	20	Zoom Wheel
6	Exposure Compensation Button	21	Shutter Button
7	Status Indicator	22	Continuous Capture Button
8	i Button	23	Fast Video Recording Button
9	Menu Button	24	Power Switch
10	Display Button	25	Mode Dial
11	Playback Button	26	Flash Button
12	AF Button/Arrow Button (Up)	27	Speaker
13	Flash Button/Arrow Button (Right)	28	Tripod Receptacle
14	Delete Button/Self-Timer Button/Arrow Button (Down)	29	Battery Cover
15	Macro Button/Arrow Button (Left)		

## 2 Inserting the Battery

1. Open the battery cover.
2. Insert the battery into the battery slot in the correct position as shown in the following diagram.
3. Close the battery cover.

## 3 Setting the Date/Time/Language





1. Push ON/OFF to turn the camera on and the language menu will appear. Use the Up/Down/Left/Right button to select a language, then press  to confirm the language.
2. Use the Up/Down/Left/Right Button again to set the date and time, and press  to confirm.

## 4 Taking a Picture

1. Hold the camera securely.
2. Use the zoom toggle Wheel to select Tele or Wide positions to zoom in or out on your subject.
3. Press the Shutter Button half way to focus on the subject. When the focus box turns green, press the Shutter Button completely down to take the picture.

## 5 Using the mode dial





This camera provides a convenient mode dial that allows you to manually switch between. Different camera settings with ease. Available modes are listed below:





	Auto Mode		Face Beautifier
<b>P</b>	Program AE		Panorama Mode
<b>S</b>	Shutter priority	<b>SCN</b>	Scene Mode
<b>A</b>	Aperture priority		Movie Mode
<b>M</b>	Manual Mode	<b>CS</b>	Custom Settings

## 6 Additional Features

1. Panorama mode: Panorama Mode allows you to create a panoramic picture. The camera will create a panoramic photo by stitching individual images taken in panorama mode.
2. Using quick recording: In shooting mode, press Recording button  to begin recording video. When you are finished, press the Recording button again or the Shutter key to stop recording. The camera will store the video and return to shooting mode.

## 7 Using the menu button

To change the settings in each mode, press  button, press  to move between options, select  setting menu, then press  button to select and save menu option.

	Photo Setup		General Setup
	Transmission		File/Software

## 8 Flash Mode

Press the flash button  to open the flash as needed.





## Quick Start Guide

快速指南  
快速入门指南



The Kodak trademark and trade dress are used under license from Kodak.

柯達商標及商品外觀皆獲得柯達授權使用。

柯达商标及商品外观都获得柯达授权使用。

© 2013 by JK Imaging Ltd. All rights reserved.

1411 W. 190th Street, Suite 550, Gardena, CA 90248, USA

www.kodakcamera.jkilt.com



CR209081599-0

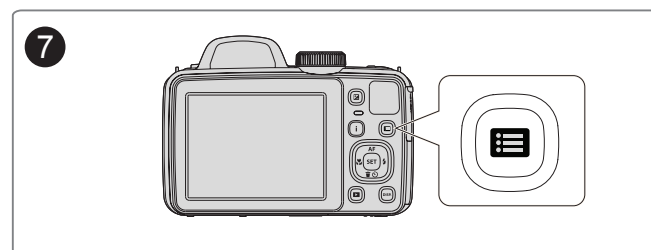
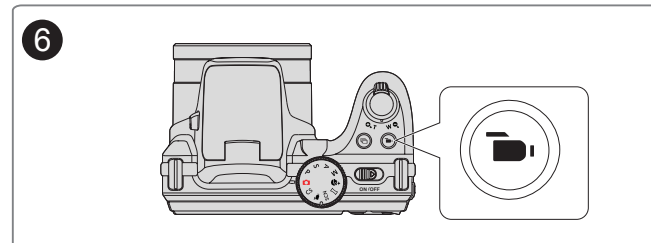
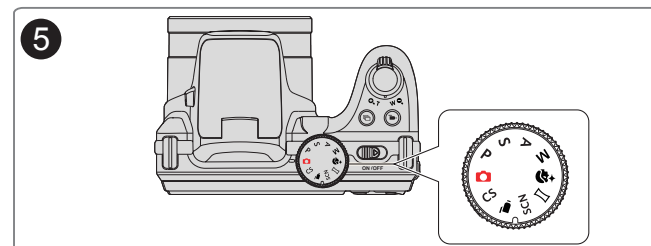
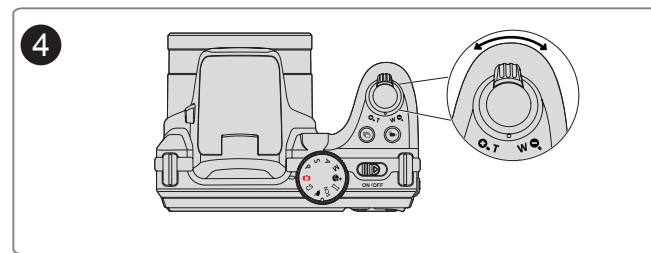
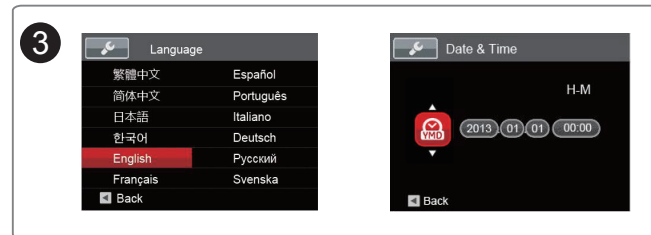
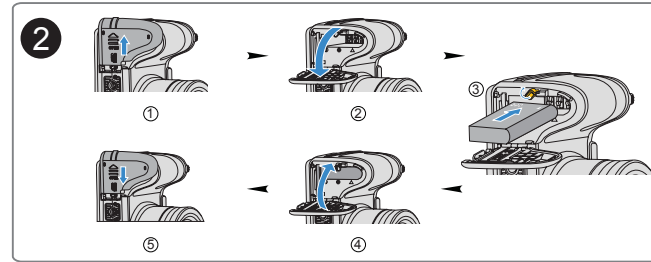
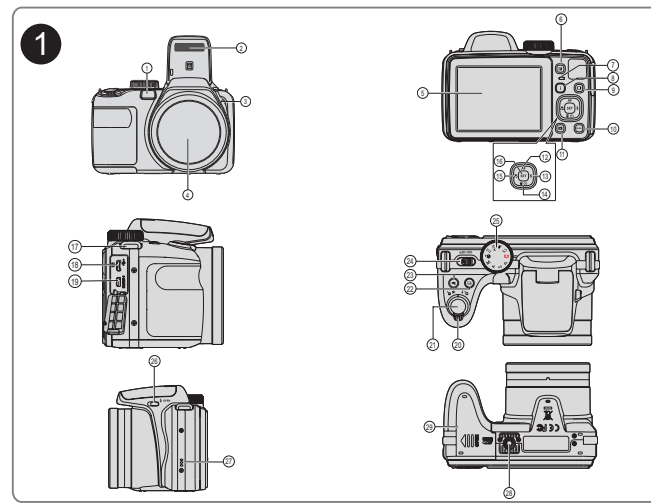

### 1 Camera Views

1	AF Assist Beam/Timer Indicator	16	SET Button
2	Flash Lamp	17	Strap Buckles
3	Microphone	18	USB Port
4	Lens	19	HDMI Port
5	LCD Screen	20	Zoom Lever
6	Exposure Compensation Button	21	Shutter Button
7	Status Indicator	22	Continuous Capture Button
8	i Button	23	Fast Video Recording Button
9	Menu Button	24	Power Switch
10	Display Button	25	Mode Dial
11	Playback Button	26	Flash Button
12	AF Button/Arrow Button (Up)	27	Speaker
13	Flash Button/Arrow Button (Right)	28	Tripod Receptacle
14	Delete Button/Self-Timer Button/Arrow Button (Down)	29	Battery Cover
15	Macro Button/Arrow Button (Left)		

### 2 Inserting the Battery

1. Open the battery cover.
2. Insert the battery into the battery slot in the correct position as shown in the following diagram.
3. Close the battery cover.

### 3 Setting the Date/Time/Language

1. Push ON/OFF to turn the camera on and the language menu will appear. Use the Up/Down/Left/Right button to select a language, then press **SET** to confirm the language.
2. Use the Up/Down/Left/Right Button again to set the date and time, and press **SET** to confirm.

### 4 Taking a Picture

1. Hold the camera securely.
2. Use the Zoom Lever to select Tele or Wide positions to zoom in or out on your subject.
3. Press the Shutter Button half way to focus on the subject. When the focus box turns green, press the Shutter Button completely down to take the picture.

### 5 Using the mode dial

This camera provides a convenient mode dial that allows you to manually switch between. Different camera settings with ease. Available modes are listed below:

	Auto Mode		Face Beautifier
	Program AE		Panorama Mode
	Shutter priority		SCN Scene Mode
	Aperture priority		Movie Mode
	Manual Mode		Custom Settings

### 6 Additional Features

1. Panorama mode: Panorama Mode allows you to create a panoramic picture. The camera will create a panoramic photo by stitching individual images taken in panorama mode.
2. Using quick recording: In shooting mode, press Recording button to begin recording video. When you are finished, press the Recording button again or the Shutter key to stop recording. The camera will store the video and return to shooting mode.

### 7 Using the menu button

To change the settings in each mode, press button, press to move between options, select setting menu, then press **SET** button to select and save menu option.

	Photo Setup		General Setup
	Transmission		File/Software

### 8 Flash Mode

Press the flash button to open the flash as needed.

### 1 相機各面視圖

1	自動對焦輔助燈/計時器指示燈	16	確定按鈕
2	閃光燈	17	背帶扣
3	麥克風	18	USB連接埠
4	鏡頭	19	HDMI連接埠
5	LCD螢幕	20	變焦桿
6	曝光補償按鈕	21	快門按鈕
7	狀態顯示燈	22	連拍按鈕
8	i按鈕	23	快速錄影按鈕
9	選單按鈕	24	電源開關
10	DISP.按鈕	25	模式盤
11	回放按鈕	26	閃光燈按鈕
12	AF按鈕/方向按鈕 (上)	27	揚聲器
13	閃光燈按鈕/方向按鈕 (右)	28	三腳架固定孔
14	刪除按鈕/自拍按鈕/方向按鈕 (下)	29	電池蓋
15	近拍按鈕/方向按鈕 (左)		

### 2 插入電池

1. 開啟電池蓋。
2. 將電池依圖示方向正確裝入電池槽中。
3. 關上電池蓋。

### 3 設定日期/時間/語言

1. 推動 ON/OFF 將相機開機，LCD 將顯示語言設定選單。使用向上/向下/向左/向右按鈕選擇語言，然後按 **SET** 確認語言。
2. 使用向上/向下/向左/向右按鈕設置日期和時間，然後按 **SET** 確認。

### 4 拍照

1. 握緊相機。
2. 將變焦桿切換至相機的望遠端 (T) 或廣角端 (W) 位置，即可放大或縮小您欲拍攝的對象。
3. 輕按快門按鈕將焦距對準拍攝物體中央，當LCD出現綠色對焦框時，完全按下快門拍攝照片。

### 5 使用模式盤

相機提供一個方便的模式盤，可讓您輕鬆切換各個模式。以下列出所有可選擇的模式：

	自動模式		美顏效果
	程序自動曝光		全景模式
	快門先決		場景模式
	光圈先決		錄影模式
	手動模式		使用者自定義

### 6 特色功能說明

1. 全景合成模式：您可利用自動全景合成模式來拍攝超廣角的全景照片，相機會自動將您所拍攝照片合成一張全景照片。
2. 使用快速錄影：在拍攝模式下，按壓錄影快捷按鈕 ，畫面將直接進入錄影狀態並進行錄影。錄影完成後，再按壓錄影快捷按鈕或快門按鈕，即可存儲動畫，並返回到拍攝畫面。

### 7 使用菜單按鈕

在所有模式中均可開啟設定選單，只要按下 鍵，按壓 按鈕切換，選擇 設定選單，按 **SET** 進入。

	相片設定		基本設定
	連接設定		檔案與軟體設定

### 8 閃光燈模式顯示

按壓閃光燈彈起 按鈕，閃光燈即可彈起。

## 1 相机概览

1	自动对焦辅助灯/计时器指示灯	16	确定按钮
2	闪光灯	17	背带扣
3	麦克风	18	USB连接埠
4	镜头	19	HDMI连接埠
5	LCD荧幕	20	变焦杆
6	曝光补偿按钮	21	快门按钮
7	状态显示灯	22	连拍按钮
8	i按钮	23	快速录影按钮
9	选单按钮	24	电源开关
10	DISP按钮	25	模式盘
11	回放按钮	26	闪光灯按钮
12	AF按钮/方向按钮（上）	27	扬声器
13	闪光灯按钮/方向按钮（右）	28	三脚架固定孔
14	删除按钮/自拍按钮/方向按钮（下）	29	电池盖
15	近拍按钮/方向按钮（左）		

## 2 装入电池

- 打开电池盖。
- 将电池依图示方向正确装入电池槽中。
- 关上电池盖。

## 3 设置日期/时间/语言

- 推动 ON/OFF 打开相机，LCD上会出现语言设定选单。使用上下左右按钮选择一个语言，然后按 **SET** 确认语言。
- 使用上下左右按钮设置日期和时间，然后按 **SET** 确认。

## 4 拍照

- 牢牢握住相机。
- 将变焦杆切换至相机的远摄位置（T）或广角位置（W），即可放大或缩小您要拍摄的对象。
- 半按快门按钮进行对焦，当LCD出现绿色对焦框时，完全按下快门拍照。

## 5 使用模式盘

相机提供一个方便的模式盘，可让您轻松切换各个模式。以下列出所有可选择的模式：

	自动模式		脸部美肤
<b>P</b>	AE程序		全景模式
<b>S</b>	快门优先级	<b>SCN</b>	场景模式
<b>A</b>	光圈优先		录影模式
<b>M</b>	手动模式	<b>CS</b>	用户自定义

## 6 特色功能说明

- 全景合成模式：**您可利用自动全景合成模式来拍摄超广角的全景照片，相机会自动将您所拍摄照片合成一张全景照片。
- 使用快速录影：**在拍摄模式下，按压录影快捷按钮 ，画面将直接进入录影状态并进行录影。录影完成后，再按录影快捷按钮或快门按钮，即可存储动画，并返回到拍摄动画画面。

## 7 使用菜单按钮

在所有模式中均可开启设定选单，只要按下  键，按压 **▲▼** 按钮切换，选择  设定选单，按 **SET** 进入。

	相片设置		一般设置
	传输		文件/软件

## 8 闪关灯模式显示

按压闪光灯弹起  按钮，闪光灯即可弹起。